

HE 耐高温, 长寿命, 高稳定 (CD26GE)

- 保证寿命：130°C 3000 小时, 105°C 12000 小时。Ensure life: 130°C 3000 hrs, 105°C 12000 hrs.
- 耐高温, 长寿命, 高稳定。High temperature, long life, high stability.
- 专为高端 LED 照明、电子节能灯、电子镇流器设计。
Especially designed for LED lighting, electronic energy saving lamps, electronic ballast.
- 符合 RoHS。RoHS Compliant.

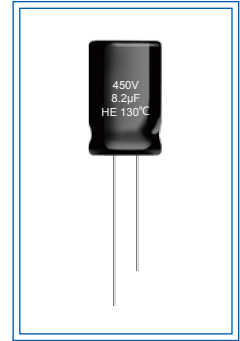

主要技术性能 Specifications

项目 Item	特性 Performance Characteristics							
工作温度范围 Operating Temperature Range	-40~+130°C (160~400V) -25~+130°C (450V)							
额定电压范围 Rated Voltage Range	160~450V							
标称容量范围 Nominal Capacitance Range	1~220µF							
标称容量允许偏差 Capacitance Tolerance	±20%(+20°C, 120Hz)							
漏电流 Leakage Current	160~400V	450V					I: 漏电流 Leakage current (µA) C: 静电容量 Nominal capacitance (µF) V: 额定电压 Rated Voltage (V) (20°C, 2 分钟 minutes)	
	$I \leq 0.02CV + 10\mu A$	$I \leq 0.03CV + 10\mu A$						
损耗角正切值 (tgδ) Dissipation Factor (+20°C, 120Hz)	$U_R(V)$	160	200	250	350	400	450	
	tgδ	0.15	0.15	0.15	0.20	0.20	0.20	
温度特性 Temperature Characteristics (Impedance ratio at 120Hz)	$U_R(V)$	160	200	250	350	400	450	
	Z-25°C / +20°C	3	3	3	5	5	6	
	Z-40°C / +20°C	6	6	6	6	6	-	
耐久性 Load Life	在 130°C 环境中, 连续加载额定直流电压 3,000 小时后; 或者在 105°C 环境中, 连续加载直流电压与额定纹波电流 (所加电压峰值不超过额定工作电压) 12,000 小时后, 待温度恢复到 20°C 进行测量时, 应满足以下要求: After application of the rated DC voltage at 130°C 3,000 hours or application of DC voltage with rated ripple current (the voltage peak is not more than rated voltage) at 105°C 12,000 hours, measuring the parameters when the capacitors are restored to 20°C, the capacitors shall meet the requirements as below: 电容量变化率 Capacitance change: ±20% 初始测量值以内 ±20% of the initial measured value 损耗角正切值 Dissipation factor: ≤ 2 倍初始规定值 200% of the initial specified value 漏 电 流 Leakage current: ≤ 初始规定值 the initial specified value							
高温贮存 Shelf Life	在 105°C 环境中, 无负荷放置 1000 小时后, 待温度恢复到 20°C 进行测量时, 应满足以下要求: The following specifications shall be satisfied when the capacitors are restored to 20°C after exposing them for 1,000 hours at 105°C without voltage application. 电容量变化率 Capacitance change: ±20% 初始测量值以内 ±20% of the initial measured value 损耗角正切值 Dissipation factor: ≤ 2 倍初始规定值 200% of the initial specified value 漏 电 流 Leakage current: ≤ 2 倍初始规定值 200% of the initial specified value							

外形图及尺寸 Diagram of Dimensions

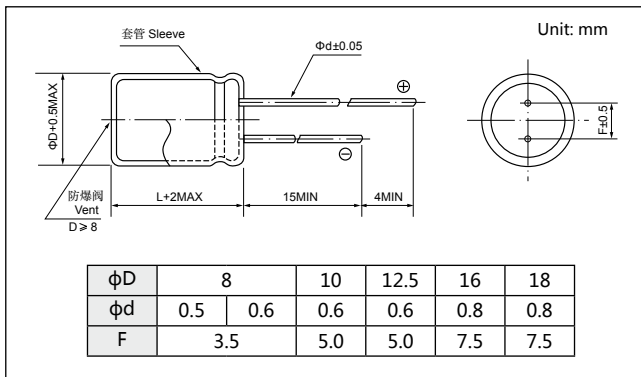

纹波电流修正系数 Multiplier for Ripple Current

频率系数 Frequency coefficient

Frequency(Hz)	120	1K	10K	100K
Coefficient	160-450	0.50	0.80	0.90

额定值标准 Standard Size

Rated Voltage (V _{dc})	Capacitance (μF)	Size ΦD×L (mm)	tanδ	Rated ripple current (mArms) 105°C /100KHz	Rated Voltage (V _{dc})	Capacitance (μF)	Size ΦD×L (mm)	tanδ	Rated ripple current (mArms) 105°C /100KHz
160V (2C)	3.3	8x12	0.15	88	350V (2V)	1	8x12	0.2	64
	4.7	8x12	0.15	96		1.5	8x12	0.2	70
	5.6	8x16	0.15	102		1.8	8x12	0.2	78
	6.8	8x16	0.15	110		2.2	8x16	0.2	88
	8.2	8x16	0.15	180		2.8	8x16	0.2	96
	10	8x16	0.15	250		3.3	8x16	0.2	110
	15	8x20	0.15	340		4.7	8x20	0.2	130
	22	10x20	0.15	500		5.6	8x20	0.2	180
	33	10x20	0.15	525		6.8	10x16	0.2	220
		12.5x20	0.15	550			10x20	0.2	232
	47	12.5x20	0.15	660		8.2	12.5x20	0.2	238
		12.5x25	0.15	695			12.5x25	0.2	245
	68	12.5x25	0.15	760		10	10x20	0.2	280
		16x20	0.15	760			12.5x20	0.2	294
	100	16x25	0.15	1120		15	12.5x20	0.2	400
		18x20	0.15	1120			12.5x25	0.2	420
150	16x30	0.15	1360	22	12.5x20	0.2	525		
	18x25	0.15	1360		12.5x25	0.2	540		
220	18x25	0.15	1400	33	16x20	0.2	630		
200V (2D)	2.8	8x12	0.15		80	16x25	0.2	650	
	3.3	8x12	0.15	92	47	16x25	0.2	760	
	4.7	8x12	0.15	100	68	16x30	0.2	850	
	5.6	8x16	0.15	108		18x25	0.2	850	
	6.8	8x16	0.15	118	100	18x35	0.2	1300	
	8.2	10x16	0.15	180	400V (2G)	1	8x16	0.2	72
	10	10x16	0.15	250		1.5	8x16	0.2	84
	15	10x20	0.15	358		1.8	8x16	0.2	85
	22	10x20	0.15	500		2.2	10x16	0.2	92
		12.5x20	0.15	525		2.8	10x16	0.2	100
	33	12.5x20	0.15	600		3.3	10x16	0.2	110
		12.5x20	0.15	660		4.7	10x20	0.2	130
	47	12.5x25	0.15	695		5.6	12.5x20	0.2	180
		16x20	0.15	760		6.8	10x16	0.2	220
	68	16x25	0.15	800			12.5x20	0.2	232
		100	16x30	0.15		1180	8.2	12.5x20	0.2
18x20	0.15		1120	10		10x20	0.2	280	
150	18x30	0.15	1430			12.5x20	0.2	294	
	220	18x35	0.15	1700		15	12.5x25	0.2	420
250V (2E)	2.2	8x12	0.15	80		22	16x25	0.2	560
	2.8	8x12	0.15	90		33	16x30	0.2	674
	3.3	8x12	0.15	100	47	18x30	0.2	884	
	4.7	8x16	0.15	120	68	18x40	0.2	1100	
	5.6	8x16	0.15	140	100	18x50	0.2	1470	
	6.8	8x16	0.15	160	450V (2W)	1.5	8x16	0.2	88
	8.2	10x16	0.15	180		1.8	8x16	0.2	90
	10	10x16	0.15	265		2.2	8x16	0.2	96
		10x20	0.15	280		2.8	10x16	0.2	100
	15	10x20	0.15	380		3.3	10x16	0.2	110
	22	12.5x20	0.15	525		4.7	10x16	0.2	130
		12.5x20	0.15	610		5.6	10x20	0.2	180
	33	12.5x25	0.15	630		6.8	12.5x20	0.2	232
		12.5x25	0.15	720		8.2	12.5x20	0.2	262
	47	16x25	0.15	760		10	12.5x20	0.2	320
		16x30	0.15	850		15	12.5x25	0.2	420
68	18x20	0.15	850	16x25			0.2	560	
	100	16x30	0.15	1200		18x20	0.2	560	
18x30		0.15	1260	33		16x30	0.2	700	
150	18x35	0.15	1500			18x25	0.2	700	
				47		18x30	0.2	880	
				68	18x40	0.2	1000		
				100	18x50	0.2	1470		

可根据客户需要定制产品 Customer products are available on request.